

**Slide Tables**  
**Ø 16 to 32 mm****M/61200/M: Slide table with adjustable guide****M/61200/MR: Slide table with precision linear ball bearing****Stroke adjustable at each endposition****High repeatability****Compact design****Technical data**

Medium:

Compressed air, filtered, lubricated or non-lubricated

Operation:

M/61200/M Double acting with adjustable guide

M/61200/MR Double acting with precision linear ball bearing

Operating pressure:

1 to 10 bar

Operating temperature:

0°C to +80 °C

Consult our Technical Service for use below +2°C

Cylinder diameters:

16, 20, 25, 32 mm

Standard strokes:

25, 50, 75, 100 (Ø 16 mm)

25, 50, 75, 100, 150 (Ø 20, 25, 32 mm)

**Materials**

Body: Anodised aluminium

Carriage: Anodised aluminium

End covers: Anodised aluminium

Piston rod: Stainless steel (Martensitic)

Seals: Nitril rubber, Polyurethane

Linear guide: Stainless steel

Guide rail: Plastic

Buffer: Elastomer

**Ordering examples**

See page 2

**Alternative models**

See page 2

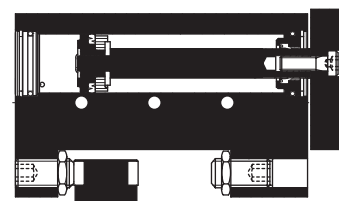
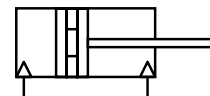



## Options selector

**M/612\*\*/\*\*/\*\*\*\***

Cylinder diameters (mm)	Substitute	Stroke length in mm	Substitute
16	16	150 max.	
20	20		
25	25		
32	32		

Variants	Substitute
Magnetic piston, adjustable guide	<b>M</b>
Magnetic piston, precision linear ball bearing	<b>MR</b>
Magnetic piston, adjustable cushioning adjustable guide or linear roller bearing	<b>on request</b>

## Switches

	Cable	Plug (M8x1)
<b>Model</b>		
Reed	M/50/LSU/.. M/50/RAC/5V	M/50/LSU/CP —
Solid state	M/50/EAP/.. M/50/EAN/..	M/50/EAP/CP M/50/EAN/CP

Model	Reed	Solid state	Voltage V a.c.	V d.c.	Current max.	Temperature °C	LED	Features	Cable/plug	Cable type	Plug-in cable Straight	90°	Catalogue page
M/50/LSU/*V	—	—	10 ... 240	10 ... 170	180 mA	-20° ... +80°	●	—	2, 5, 10 m	PVC 2 x 0,25	—	—	N 4.3.005
M/50/LSU/5U	—	—	10 ... 240	10 ... 170	180 mA	-20° ... +80°	●	—	5 m	PUR 2 x 0,25	—	—	N 4.3.005
M/50/RAC/5V	—	—	10 ... 240	10 ... 170	180 mA	-20° ... +80°	—	Changeover	5 m	PVC 3 x 0,25	—	—	N 4.3.005
M/50/LSU/CP	—	—	10 ... 60	10 ... 75	180 mA	-20° ... +80°	●	Plug M8x1	5 m	—	M/P73001/5	—	N 4.3.005
—	—	M/50/EAP/*V	—	10 ... 30	150 mA	-20° ... +80°	●	—	2, 5, 10 m	PVC 3 x 0,25	—	—	N 4.3.007
—	—	M/50/EAP/CP	—	10 ... 30	150 mA	-20° ... +80°	●	PNP, plug M8x1	5 m	—	M/P73001/5	—	N 4.3.007
—	—	M/50/EAN/*V	—	10 ... 30	150 mA	-20° ... +80°	●	—	2, 5, 10 m	PVC 3 x 0,25	—	—	N 4.3.007
—	—	M/50/EAN/CP	—	10 ... 30	150 mA	-20° ... +80°	●	NPN, plug M8x1	5 m	—	M/P73001/5	—	N 4.3.007

\* Insert cable length

Full information on switches (technical data, cable materials, dimensions etc.) please refer to relevant catalogue pages

## Accessories

	Groove key	Groove cover
Ø		
16	M/P72816	M/P72725/1000
20	M/P72816	M/P72725/1000
25	M/P72816	M/P72725/1000
32	M/P72816	M/P72725/1000

## Ordering examples

### Slide table

To order a standard Ø 32 mm bore with adjustable guide, magnetic piston, stroke 150 mm  
quote: **M/61232/M/150**

### Switches

To order a reed switch with LED and 2 m cable length  
quote: **M/50/LSU/2V**

## Warning

These products are intended for use in industrial compressed air systems only. Do not use these products where pressures and temperatures can exceed those listed under 'Technical Data'.

Before using these products with fluids other than those specified, for non-industrial applications, life-support systems, or other applications not within published specifications, consult NORGREN.

Through misuse, age, or malfunction, components used in fluid power systems can fail in various modes.

The system designer is warned to consider the failure modes of all component parts used in fluid power systems and to provide adequate safeguards to prevent personal injury or damage to equipment in the event of such failure.

System designers must provide a warning to end users in the system instructional manual if protection against a failure mode cannot be adequately provided.

System designers and end users are cautioned to review specific warnings found in instruction sheets packed and shipped with these products.



## Forces and Loading Values

### Theoretical Forces

Model	Theoretical forces (N) at 6 bar	
	Outstroke	Instroke
M/61216/...	120	102
M/61220/...	188	158
M/61225/...	294	247
M/61232/...	482	414

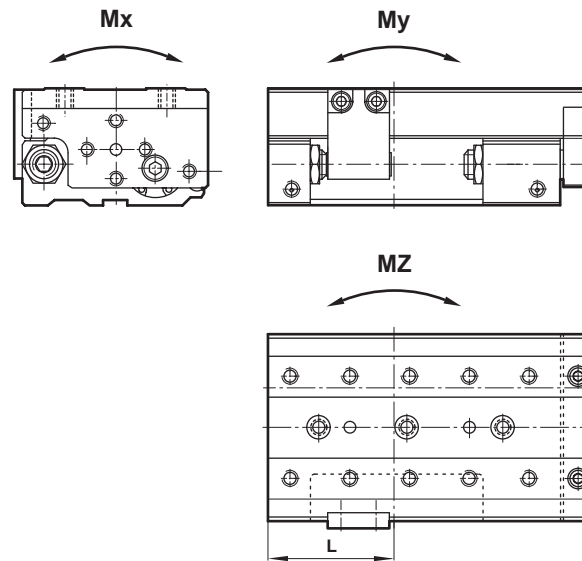

### Theoretical moments

Model	Theoretical moments (Nm)			L (mm)
	Mx	My	Mz	
M/61216/M/25	10	14	14	29
M/61216/M/50	10	14	14	29
M/61216/M/75	10	14	14	29
M/61216/M/100	10	14	14	29
M/61220/M/25	14	14	14	29
M/61220/M/50	14	14	14	29
M/61220/M/75	20	20	20	39
M/61220/M/100	28	28	28	53
M/61220/M/150	28	28	28	53
M/61225/M/25	26	20	20	29
M/61225/M/50	26	20	20	29
M/61225/M/75	52	40	40	53
M/61225/M/100	52	40	40	53
M/61225/M/150	52	40	40	53
M/61232/M/25	32	20	20	29
M/61232/M/50	32	20	20	29
M/61232/M/75	64	40	40	53
M/61232/M/100	64	40	40	53
M/61232/M/150	64	40	40	53

Model	Theoretical moments (Nm)			L (mm)
	Mx	My	Mz	
M/61216/MR/25	24	14	14	28
M/61216/MR/50	24	14	14	28
M/61216/MR/75	24	14	14	28
M/61216/MR/100	24	14	14	28
M/61220/MR/25	26	10	10	33
M/61220/MR/50	26	10	10	33
M/61220/MR/75	26	10	10	33
M/61220/MR/100	26	10	10	33
M/61220/MR/150	26	10	10	33
M/61225/MR/25	66	34	34	42
M/61225/MR/50	66	34	34	42
M/61225/MR/75	66	34	34	42
M/61225/MR/100	66	34	34	42
M/61225/MR/150	66	34	34	42
M/61232/MR/25	120	48	48	47
M/61232/MR/50	120	48	48	47
M/61232/MR/75	120	48	48	47
M/61232/MR/100	120	48	48	47
M/61232/MR/150	120	48	48	47

### Loading values for Slide Tables

A requirement for best using these slide tables please use our calculation programme Slide-Calc. It is available on request. Slide-Calc is suitable for all PC's having Windows '95 and higher.



Basic dimensions, cylinder Ø 16 mm

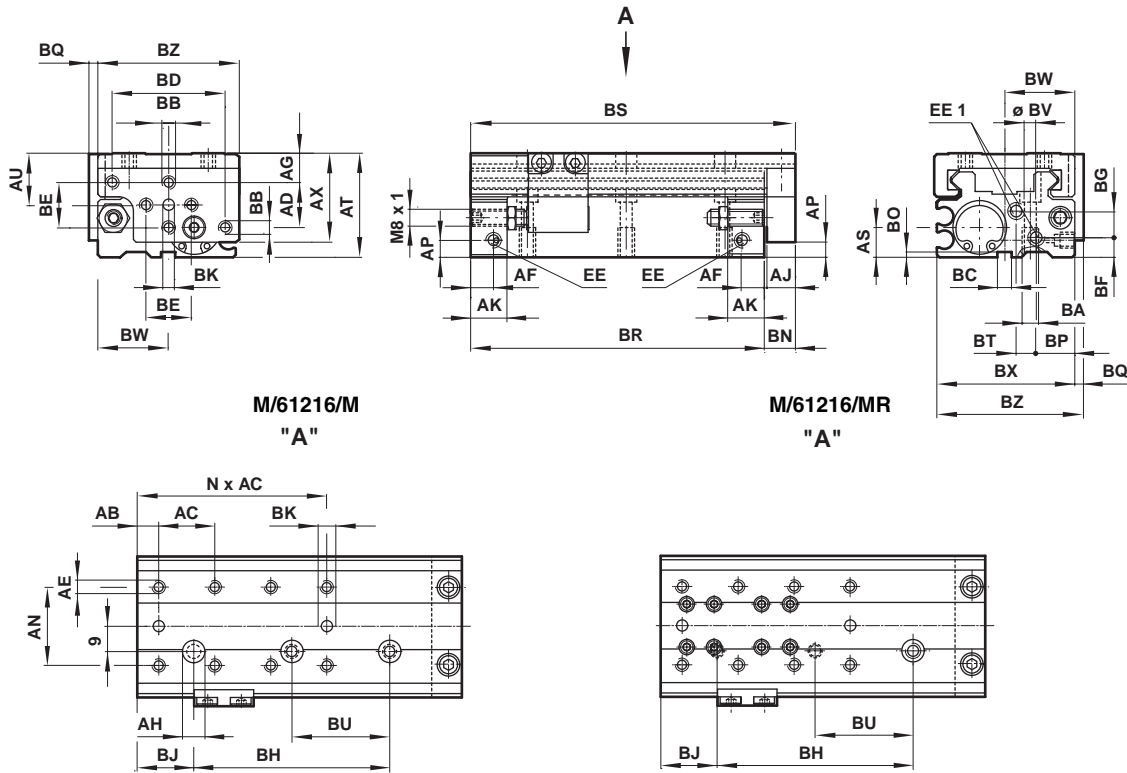

M/61216/M  
"A"

M/61216/MR  
"A"

Ø	AB	AC	AE	AD	AG	Ø AH	AJ	AN	AP	AS	AT	AU	AX	BA	BB	Ø BC <sup>H7</sup>
16	7,5	20	M4 – 5,5 deep	16	10,5	8	10	28	6	10,5	37	18,5	31,5	M5 – 8 deep	M4	5
Ø	BD	BE	BF	BG	Ø BK <sup>H7</sup>	BN	BO	BP	BQ	BT	Ø BV	BW	BX	BZ	EE	EE 1
16	40	16	7	9,3	4	11	2	14	2,5	6,6	4,2	25	49	50	M5 – 5,5 deep	M5 – 7 deep

Cylinder Ø 16 mm

Model	Stroke	AF	AK	BH	BJ	BR	BS	BU	N	kg
M/61216/M/25	25	8	14	40	20	81	92	–	2	0,28
M/61216/MR/25	25	8	14	40	20	81	92	–	2	0,34
M/61216/M/50	50	8	14	70	20	106	117	35	3	0,35
M/61216/MR/50	50	8	14	70	20	106	117	35	3	0,41
M/61216/M/75	75	8	14	80	20	131	142	40	4	0,45
M/61216/MR/75	75	8	14	80	20	131	142	40	4	0,54
M/61216/M/100	100	8	14	120	20	156	167	60	5	0,52
M/61216/MR/100	100	8	14	120	20	156	167	60	5	0,62



Basic dimensions, cylinder Ø 20 to 25 mm

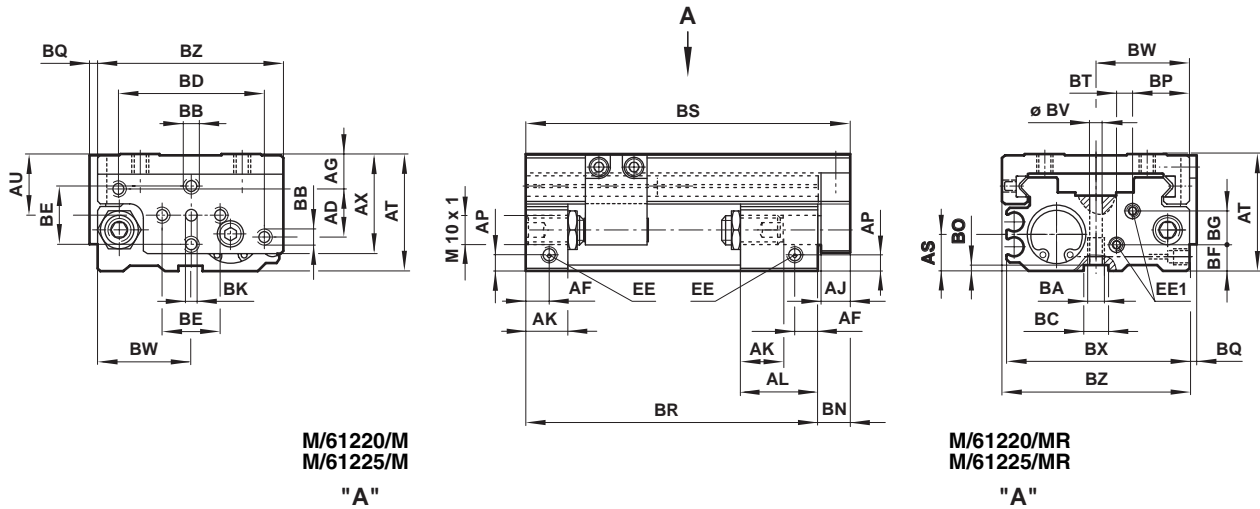

M/61220/M  
M/61225/M

"A"

M/61220/MR  
M/61225/MR

"A"

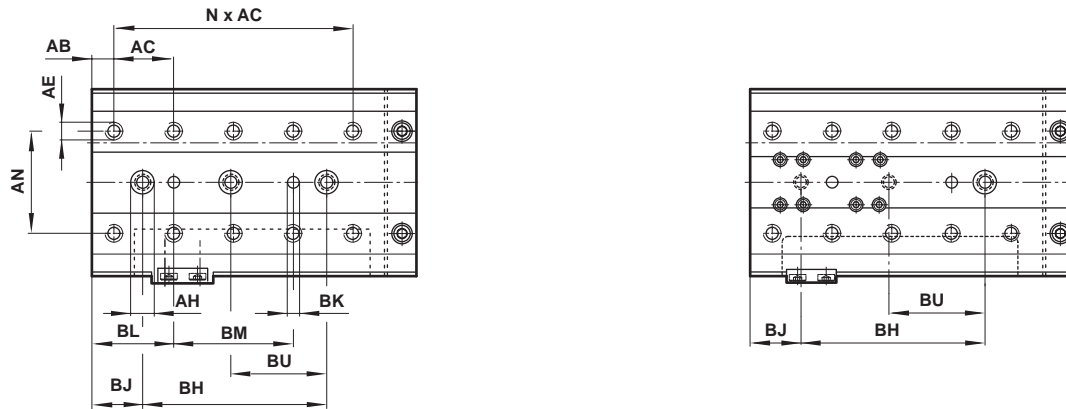

Ø	AB	AC	AE	AD	AG	Ø AH	AJ	AN	AP	AS	AT	AU	AX	BA	BB	Ø BC <sup>H7</sup>
20	7,5	25	M5 – 6,5 deep	16,5	12	8	10	35	5,5	12,5	40	20	34	M5 – 10 deep	M5	10
25	7,5	25	M5 – 8,0 deep	20	14	9	12	40	7	15	48	24	40	M6 – 10 deep	M5	10
Ø	BD	BE	BF	BG	Ø BK <sup>H7</sup>	BN	BO	BP	BQ	BT	Ø BV	BW	BX	BZ	EE	EE 1
20	50	20	9	11,5	4	11	2	19,5	2,5	5,5	4,2	32	62,5	64	M5 – 5,5 deep	M5 – 7 deep
25	65	22	12	11,5	4	13	2	19,5	3,5	12	5,1	39,5	76,2	79	M5 – 5,5 deep	M5 – 7 deep

Cylinder Ø 20 mm

Model	Stroke	AF	AK	AL	BH	BJ	BL	BM	BR	BS	BU	N	kg
M/61220/M/25	25	9	13,5	13,5	25	22,5	7,5	25	75	86	–	2	0,41
M/61220/MR/25	25	9	14,5	26,5	50	22,5	7,5	50	100	111	25	2	0,50
M/61220/M/50	50	9	13,5	13,5	50	22,5	7,5	50	100	111	25	3	0,53
M/61220/MR/50	50	9	14,5	26,5	75	22,5	32,5	50	125	136	37,5	3	0,62
M/61220/M/75	75	9	14,5	14,5	100	22,5	32,5	75	145	156	50	4	0,66
M/61220/MR/75	75	9	14,5	21,5	100	22,5	32,5	75	145	156	50	4	0,79
M/61220/M/100	100	9	14,5	14,5	100	22,5	32,5	100	180	191	50	5	0,78
M/61220/MR/100	100	9	14,5	31,5	100	22,5	32,5	100	180	191	50	5	0,94
M/61220/M/150	150	9	14,5	14,5	150	22,5	32,5	100	240	251	75	5	1,03
M/61220/MR/150	150	9	14,5	41,5	150	22,5	32,5	100	240	251	75	5	1,24

Cylinder Ø 25 mm

Model	Stroke	AF	AK	AL	BH	BJ	BL	BM	BR	BS	BU	N	kg
M/61225/M/25	25	9,5	14,5	14,5	50	17,5	7,5	50	85	98	25	2	0,65
M/61225/MR/25	25	9,5	14,5	41,5	75	22,5	32,5	50	115	128	37,5	3	0,78
M/61225/M/50	50	9,5	14,5	14,5	75	20	32,5	50	115	128	37,5	3	0,85
M/61225/MR/50	50	9,5	14,5	41,5	100	22,5	32,5	75	140	153	50	4	0,92
M/61225/M/75	75	9,5	14,5	14,5	100	22,5	32,5	100	165	178	50	5	1,05
M/61225/MR/75	75	9,5	14,5	41,5	100	22,5	32,5	100	165	178	50	5	1,26
M/61225/M/100	100	9,5	14,5	14,5	150	22,5	32,5	125	190	203	75	6	1,20
M/61225/MR/100	100	9,5	14,5	41,5	150	22,5	32,5	125	190	203	75	6	1,20
M/61225/M/150	150	9,5	14,5	14,5	150	22,5	32,5	125	240	253	75	6	1,60
M/61225/MR/150	150	9,5	14,5	41,5	150	22,5	32,5	125	240	253	75	6	1,60



Basic dimensions, cylinder Ø 32 mm

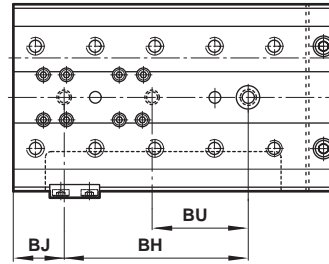
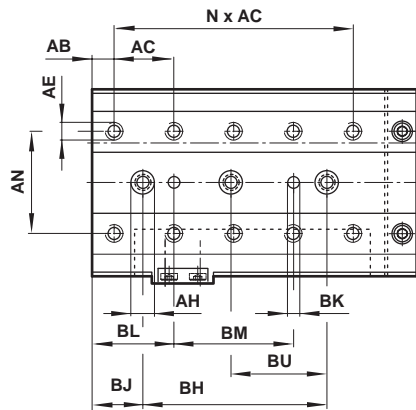
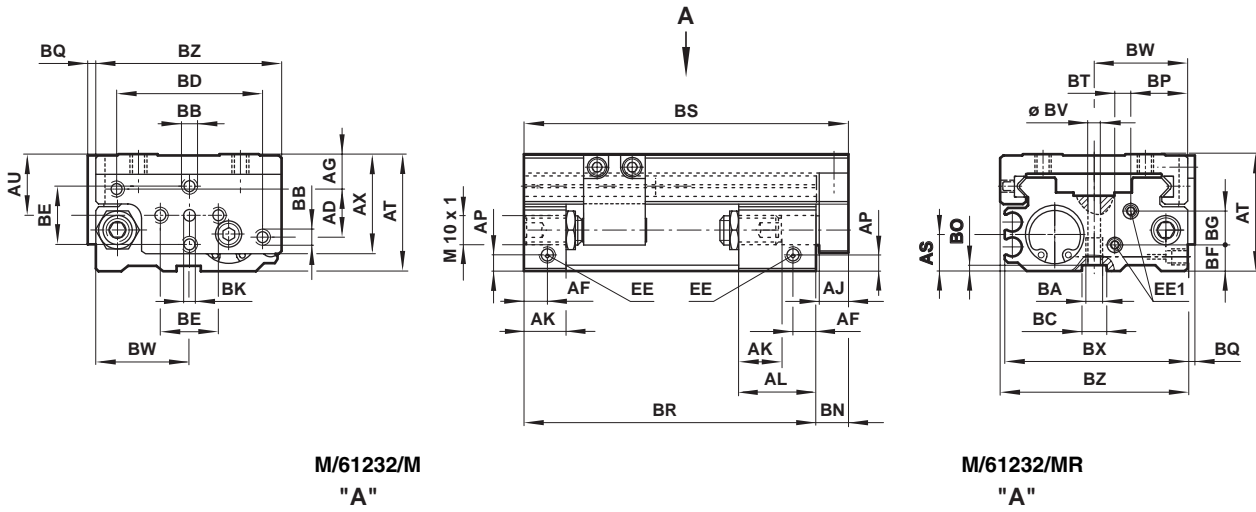

Ø	AB	AC	AE	AD	AG	Ø AH	AJ	AN	AP	AS	AT	AU	AX	BA	BB	Ø BC <sup>H7</sup>
32	7,5	30	M6 – 8,5 deep	26	15	11	12	50	10	19	57	28	48	M8 – 14 deep	M6	10
Ø	BD	BE	BF	BG	Ø BK <sup>H7</sup>	BN	BO	BP	BQ	BT	Ø BV	BW	BX	BZ	EE	EE 1
32	75	28	17,5	13,5	5	13	2	24,5	3,5	12	6,6	46	90,5	92	G1/8 – 10 deep	G1/8 – 10 deep

Cylinder Ø 32 mm

Model	Stroke	AF	AK	AL	BH	BJ	BL	BM	BR	BS	BU	N	kg
M/61232/M/25	25	8	16	16	50	20	7,5	50	90	103	25	2	1,00
M/61232/MR/25	25	8	19	43	75	22,5	37,5	50	120	133	37,5	3	1,20
M/61232/M/50	50	11	19	43	90	30	40	60	145	158	45	3	1,32
M/61232/MR/50	50	11	19	43	90	30	37,5	60	145	158	45	3	1,70
M/61232/M/75	75	11	19	43	120	30	40	90	170	183	50	4	1,63
M/61232/MR/75	75	11	19	43	120	30	37,5	90	170	183	50	4	1,96
M/61232/M/100	100	11	19	43	130	30	40	100	195	208	60	5	1,86
M/61232/MR/100	100	11	19	43	130	30	37,5	100	195	208	60	5	2,23
M/61232/M/150	150	11	19	43	150	30	40	120	245	258	75	5	2,48
M/61232/MR/150	150	11	19	43	150	30	37,5	120	245	258	75	5	2,98

Spares

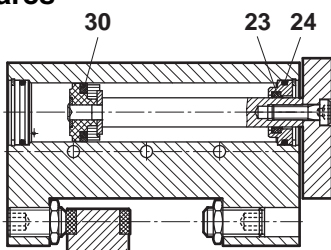

Ø	Model	Spares kit	Comprising Item	Description	Quantity
16	M/61216/M, M/61216/MR	QM/61216/M/88	30	Seal	1
20	M/61220/M, M/61220/MR	QM/61220/M/88	23	Seal	1
25	M/61225/M, M/61225/MR	QM/61225/M/88	24	O-Ring	2
32	M/61232/M, M/61232/MR	QM/61232/M/88			